

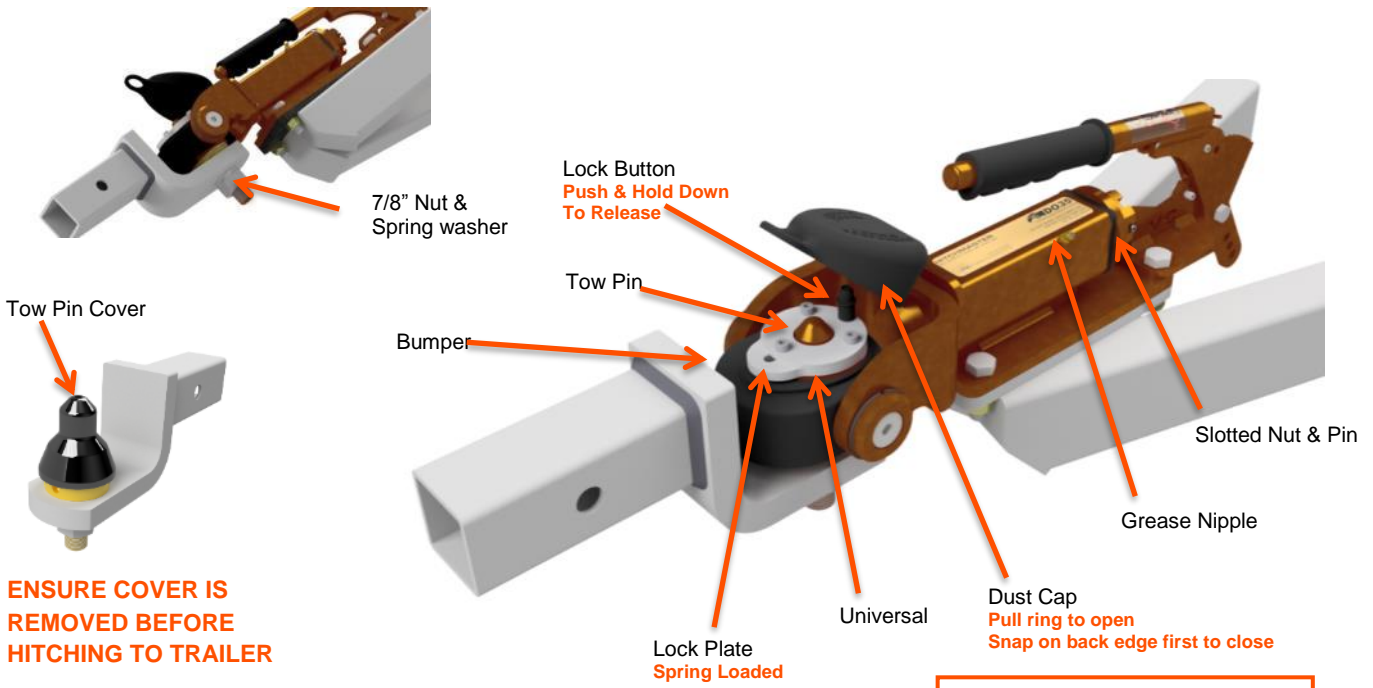

**CUSTOMER INFORMATION SHEET – NO. 16**

**CRUISEMASTER™ DO35 V2 – DROP-ON COUPLING**



**ADR RATED TO**

**Mounting the DO35 COUPLING onto trailer drawbar:**

<b>Bolt- on</b>	Always use at least four mounting bolts (two in front holes/slots) to secure Coupling to Trailer. Use minimum M12 Class 8.8 or ½" Grade 5 bolts with Nylon insert nuts or spring washers. Fasten to 75N.m and 90N.m respectively
<b>Weld-on</b>	Run weld fully down both sides of the base plate, with a minimum 50mm long weld on the front of the base plate.

**A drawbar weight of at least 50kg and not exceeding 350kg is recommended**

**1 Mounting the DO35 TOW PIN onto vehicle Tow bar:**

- Fit Tow Pin to Tow bar using new spring washer, 7/8" UNF nut and C-spanner supplied.
- Tighten 7/8" nut to 440N.m (325lbs.ft).
- **Cruisemaster™ DO35 can be used with load distribution hitches' providing the coupling movement is not obstructed, the maximum downward load of 350kg is not exceeded and the correct adaptor bracket or Tow Pin is used. With a WDH adaptor attached to the vehicle, clearance should also be checked to ensure the trailer drawbar**

doesn't foul particularly in reversing situations. Refer to website or CIS 08 for WDH options.

## 2 COUPLING:

For coupling the DO35 to your vehicle, we recommend the following:

1. Trailer should only be coupled (and uncoupled) on level ground.
2. Make sure Tow Pin and Universal is free of sand, dirt and foreign objects, and is lightly lubricated.
3. Ensure Tow Pin Cover is removed from Tow Pin.
4. Raise height of trailer coupling above vehicle Tow Pin by adjusting Jockey Wheel or Stand.
5. Push and hold Lock Button down, push the Lock Plate to full open position until the Lock Button is able to spring back
6. Align Coupling over Tow Pin by moving either vehicle or trailer, and lower Coupling onto Tow Pin. Ensure that Universal is fully seated on Tow Pin, Ensure Tow Pin protrudes through locking plate.
7. Push the Lock Button to release the plate into the locked position.
8. Assemble the dust cover by snapping in the back edge of the seal first and then pushing down on the front. Dust cover will emit an audible snap when assembled correctly.

### MAINTENANCE & SAFETY

- Keep hands and fingers clear of coupling when attaching.
- Ensure trailer safety chains are attached whilst coupling or uncoupling.
- Keep Tow Pin and Universal mating surfaces clean and lightly greased at all times.
- Check condition of Tow Pin O-Ring and replace if necessary (VC part no 18D-DO35-101).
- Regularly lubricate grease points with multi-purpose grease.
- Check all bolts regularly for tightness.
- Do not use Tow Pin or Coupling for recovery purposes.
- If excessive free movement or clearance is detected in coupling bushes, the slotted nut should be tightened by a competent person. This may be required after some use, particularly on heavier trailers. See maintenance instructions or call Cruisemaster™ for further information.
- Flush with water if locking mechanism does not open fully due to dirt ingress.

**V2-R**  
Raised

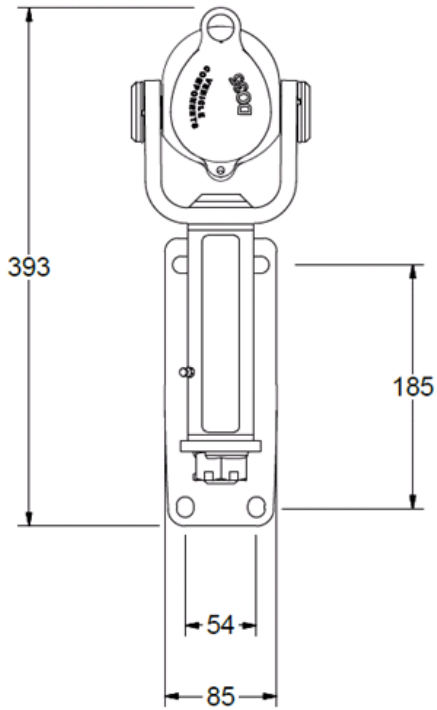

**V2-I**  
Integrated

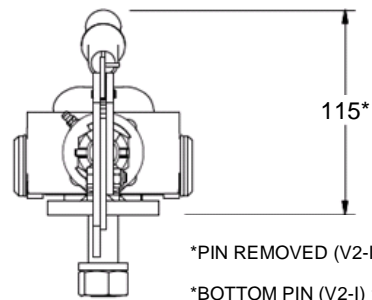
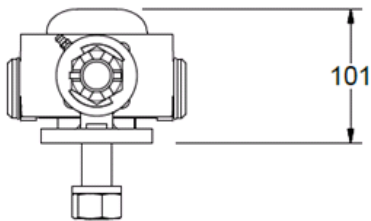
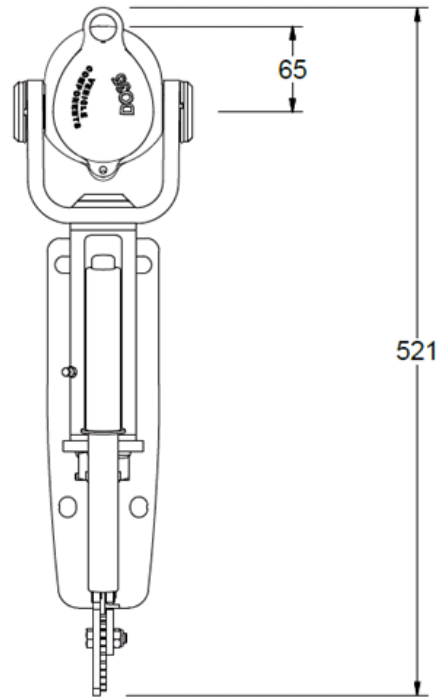

- \*PIN REMOVED (V2-I) 95
- \*BOTTOM PIN (V2-I) 115
- \*TOP PIN (V2-I) 155

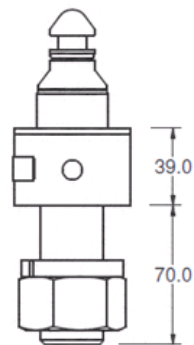
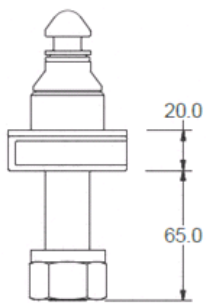

**TP-W**

22mm (7/8") Tow Pin

**Supplied standard with all DO35 models**  
For use with Hayman Reese CLASSIC Weight Distribution Hitch

**TP-WX**

32mm (1-1/4") Tow Pin

For use with Hayman Reese STANDARD Weight Distribution Hitch

## CRUISEMASTER™ DO35 BI-LOCK SECURITY PIN

Ensure the safety of your camper or caravan when you're not there with the ultimate coupling lock. The Cruisemaster™ Bi-Lock assembly consists of a dummy pin, two keys, a lock and a dust cover. Its components are made of stainless steel.

How does it work? The dummy pin is to be inserted into the DO35 & DO45 universal joint from the top end and the tip of the pin will protrude out at the bottom. The lock is then fitted to the protruding end of the pin and can be locked with a key. The coupling becomes inoperable which prevents others being able to hitch up to your trailer or van when you're not there.

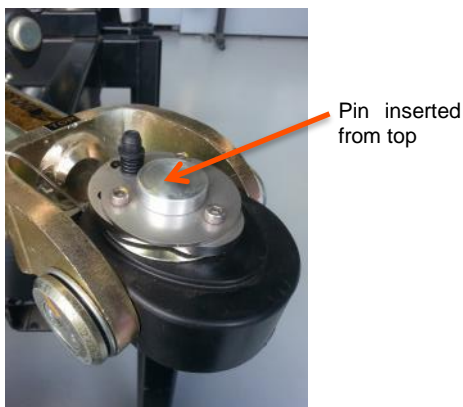

Bi-lock pin installed in DO35 coupling (Top View)

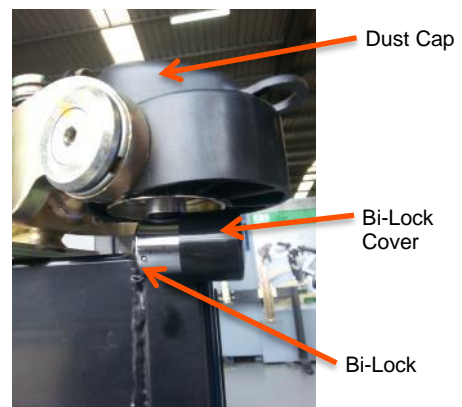

Bi-lock pin locked in DO35 coupling (Bottom View)

### Installation of Bi-Lock pin into DO35/45 coupling

- Ensure trailer is detached from vehicle
- Unlock coupling mechanism
- Drop pin through the locking mechanism from the top so the flange sits against top surface of lock
- Lock the coupling mechanism so to secure the pin in place.
- Lock the Bi-Lock to the bottom of the pin
- Place the rubber cover on to the bi-lock
- Refit coupling dust cap to cover the pin