

CUSTOMER INFORMATION SHEET – NO. 08

CRUISEMASTER™ WEIGHT DISTRIBUTION HITCH ADAPTORS

1 DO35 V2 Off-Road Drop-On Coupling

The DO35 V2 Off-Road Drop-On Coupling can be fitted to Hayman Reese Standard and Classic Weight Distribution Systems by using a suitable adaptor kit, or for the Standard, a raised height towing pin (*DO35 V3 released 06/17 does not require an adaptor for standard use*). The adaptor kit type depends on the Weight Distribution System used:

The Classic WDH series features the traditional tried and tested welded weight distribution head with trunnion style spring bars. To fit a DO35 V2 to this WDH requires the use of adaptor kit Part No 18D HM WDH2. The kit ships complete with SA5 plated extension bracket, towpin and fasteners. Installation requires a hole to be drilled through the top of the WDH to fit a M12 bolt (see detailed installation instructions below).

The Standard WDH series features a cast weight distribution head with round style spring bars, well suited to 150mm drawbar sections. Use adaptor kit Part No 18D HM WDH 3. The kit includes SA5 plated extension bracket, required fasteners and spacer. The Standard WDH can also be used with the raised height DO35 towpin (Part No 18D DO35 TP-WX) where there is sufficient clearance between the WDH drop arm and towpin.

In all cases installers should check that the coupling movement is not restricted in any way. Also check for obstruction of the WDH against the trailer drawbar at all angles as collision may occur during reversing which can damage the coupling. It is also worth noting that the application of a WDH may impose additional loads on the coupling. The DO35 is rated to a max vertical load of 350kg. Installers should ensure that they are familiar with the installation, maintenance and safety requirements as detailed in Customer Information Sheet 16 that accompanies each coupling.

Classic Series (Welded weight distribution head)

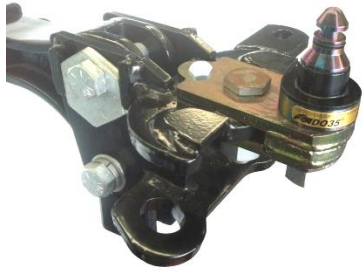

Use adaptor kit **18D HM WDH2** to fit DO35 to Hayman Reese *Classic Series* WDH

Standard Series (Cast weight distribution head)

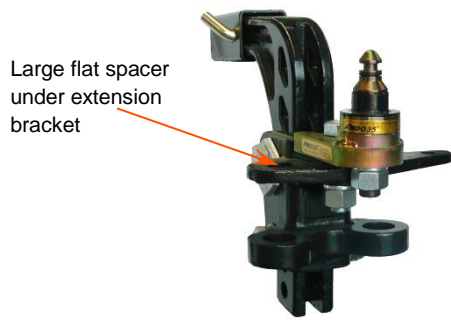

Large flat spacer under extension bracket

OR



Raised Height Towpin **18D DO35 TP-WX** with 32mm (1 1/4) thread on *Standard Series* WDH

Use adaptor kit **18D HM WDH3** to fit DO35 to Hayman Reese *Standard Series* WDH

Cruisemaster™ Part No: 18D HM WDH 2

Designed to fit Hayman Reese Classic Series WDH systems 600lb/275kg and 800lb/365kg.

1.



Top mounting plate of Hayman Reese Weight Distribution Hitch (WDH)

2.

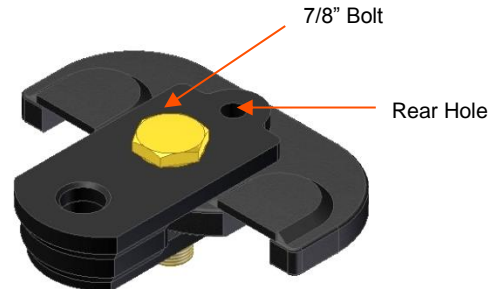

Place Cruisemaster™ Towbar Extension over WDH mounting plate and insert the 7/8" bolt. Ensure that the Towbar Extension is aligned and mark the position of the rear hole on the WDH mounting plate.

3.



Remove the Towbar Extension, centre-punch the mark and drill a Ø13mm hole through the WDH top mounting plate. Apply some paint to the drilled hole, allow to dry.

4.



Replace the Towbar Extension, insert M12 bolt and Nyloc nut, torque to 75N.m (55lbf.ft). Insert 7/8" bolt with spring washer and nut, torque to 440N.m (325lbf.ft). Fit Cruisemaster™ as per assembly instructions.

IMPORTANT

Ensure that coupling movement is not obstructed and the maximum downward load of 350kg is not exceeded.

MAINTENANCE & SAFETY

- See fitting and operating the DO35 Coupling (Cruisemaster™ Customer Information Sheet 16 – CRUISEMASTER™ DO35 ALL-TERRAIN DROP-ON COUPLING).
- Check all bolts regularly for tightness.
- Do not use Towing Pin or Coupling for recovery purposes.
- Cruisemaster™ DO35 can be used with load distribution hitches (WDH) providing the coupling movement is not obstructed and the maximum downward load of 350kg is not exceeded. With a WDH attached to the vehicle clearance should also be checked to the trailer drawbar to ensure obstruction will not occur particularly in reversing situations.
- When loading up WDH ensure ratings of coupling and towbar are not exceeded.

2 DO45 Off-Road Drop-On Coupling

The DO45 can be fitted to the Hayman Reese Super Heavy Duty Weight Distribution System without the use of an adaptor kit. The DO45 Towpin (1 ¼" UNF thread – about 32mm) bolts directly onto the WDH head.

In all cases, installers should check that the coupling movement is not restricted in any way. It is also worth noting that the application of a WDH may impose additional loads on the coupling. The DO45 is rated to a max vertical load of 450kg. Installers should ensure that they are familiar with the installation, maintenance and safety requirements as detailed in Customer Information Sheet 19 that accompanies each coupling.

Consult the Hayman Reese catalogue or website for detailed information on this WDH system.

Super Heavy Duty Series (Cast weight distribution head)



IMPORTANT

Ensure that coupling movement is not obstructed and the maximum downward load of 450kg is not exceeded.

MAINTENANCE & SAFETY

- See fitting and operating the DO45 Coupling (Cruisemaster™ Customer Information Sheet 19 – CRUISEMASTER™ DO45 ALL-TERRAIN DROP-ON COUPLING).
- Check all bolts regularly for tightness.
- Do not use Towing Pin or Coupling for recovery purposes.
- Cruisemaster™ DO45 can be used with load distribution hitches (WDH) providing the coupling movement is not obstructed and the maximum downward load of 450kg is not exceeded. With a WDH attached to the vehicle clearance should also be checked to the trailer drawbar to ensure obstruction will not occur particularly in reversing situations.
- When loading up WDH ensure ratings of coupling and towbar are not exceeded.