

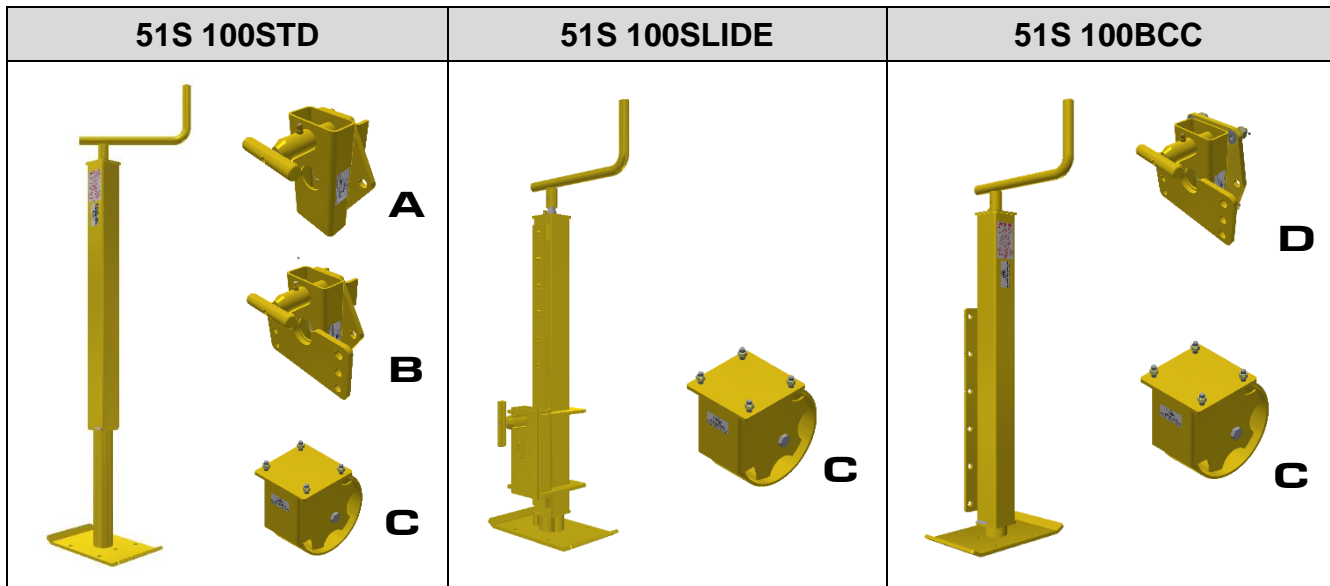

CUSTOMER INFORMATION SHEET – NO. 04

CRUISEMASTER™ SLIMLINE 2T STANDS



	Part No.	Description
A	51S 101STD W/O	Slimline Standard Weld On Swivel
B	51S 101STD B/O	Slimline Standard Bolt On Swivel
C	51S 102	Slimline Jockey Wheel
D	51S 101BCC	Slimline BCC/Utilities Swivel

The 2 Ton Slimline stand range is made in the Brisbane factory to our own exacting standards.

The design of these stands includes a full 6TPI ACME load bearing thread and automotive grade taper roller bearing giving support in both axial and sideways directions. This makes the stands light to wind yet robust enough to be specified by Councils and Mines.

The stand handles are fully sealed with an O-ring and a grease nipple is incorporated into the top for lubrication. This ensures a long, trouble free life for the mechanism. Each stand is fully SA5 plated and slide mechanisms include stainless steel components.

An optional steel wheel assembly is available with a dynamic rating of 500kgs.

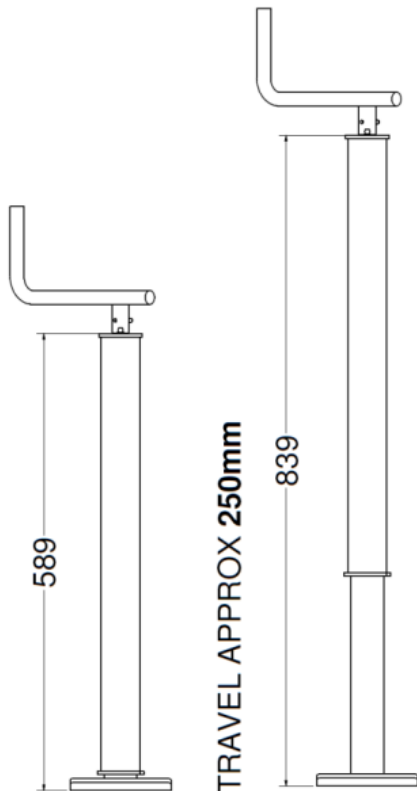

NOTES:

- All Slimline stands have a 2 tonne static / lifting load limit. This is the load that is capable of being lifted with the trailer stationary on firm and level ground with the stand installed as per Cruisemaster™ specifications.
- When a Slimline stand or swivel combination is fitted with a Slimline jockey wheel (51S 102) the stand has a maximum **dynamic load of 500kgs**. This figure is a guide only and is based on moving a trailer on firm and level ground. Ultimate strength will depend on drawbar strength, surface condition, usage etc. **Using the Slimline Jockey Wheel raises the stand by approx. 175mm**

IF IN DOUBT, PLEASE CONTACT OUR ENGINEERING DEPARTMENT FOR FURTHER INFORMATION