

ABOUT BOSCH TSC

Trailer Safety Control was invented in Australia by the team at Bosch Australia.

Bosch were the first to bring ABS to market back in 1978 and is still the market leader today.



TSC is the most advanced caravan safety system on the market. Even the most experienced drivers will encounter critical safety events outside their control.

Upgrade your safety, tow with confidence and avoid ruined holidays.



BOSCH
Trailer Safety

WHAT IS ABS

ABS (Antilock Braking) has been a mandatory feature on all new passenger vehicles for over 20 years. It is a proven, life-saving technology that drastically reduces the chances of an accident.

ABS uses advanced wheel speed sensors to monitor the precise movement of each wheel. It takes these readings up to 1000 times per second and using intelligent algorithms, can tell exactly what type and level of braking is required. The system will then control every wheel individually at lightning speed to bring the caravan back under control safely. By preventing wheel-lock, this also avoids flat-spotting tyres, which can be costly.



ABS Enabled Caravan
Suspension - Featuring
Bosch TSC



Cruisemaster
ABS Enabled



CRUISEMASTER.COM.AU

@CRUISEMASTERCOUNTRY



ABOUT ENABLED HARDWARE

All new builds by Cruisemaster featuring electric drum brakes come standard as 'ABS Compatible'. This means the suspension arm will have a unique weld ring, ABS compatible Electric Backing Plate and ABS suitable drum.

Cruisemaster 'ABS Enabled' systems include all of the required brake/arm hardware to have your Caravan or Trailers ready to connect to a Bosch TSC system.



THE CRUISEMASTER ABS ENABLED SYSTEMS USES PREMIUM AUTOMOTIVE GRADE/STYLE TECHNOLOGY IN IT'S ABS HARDWARE DIFFERENT TO THE EXISTING SYSTEMS IN THE MARKET.

FEATURES & BENEFITS

LANE CHANGE (SWERVE CONTROL)

The swerve control function recognises if you suddenly input a severe change in direction and delivers a braking pattern that will reduce the chance of jack-knifing or rollover. It will also mitigate any negative impacts from oversteering or counter-steering.

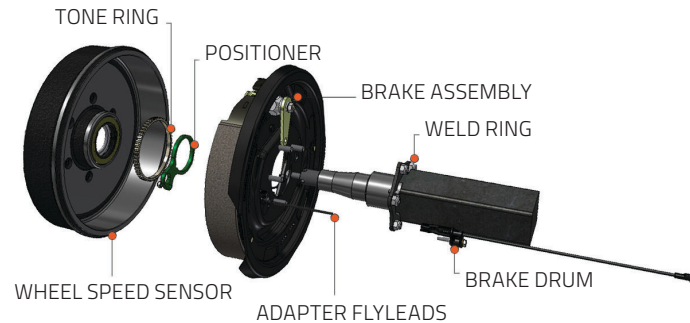

TRAILER SWAY MITIGATION

Using a more advanced array of sensors than any other system on the market, TSC instantly identifies a sway event and gently ramps in the braking to match the oscillations, rather than violently jamming on all of the brakes (as most other systems do), which can lead to more trouble.

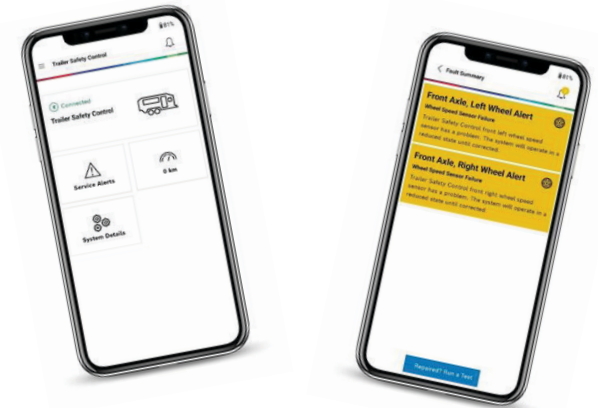

BLUETOOTH ODOMETER & BRAKE FAULT DIAGNOSTICS

Using the wheel speed sensors, TSC gives you a highly accurate reading of the mileage of your caravan, unlike GPS-based systems. Schedule preventative maintenance and servicing of your van, avoiding problems before they get too big or costly.

The system also intelligently monitors itself and notifies you if something is wrong via a Bluetooth app.

TOWING BENEFITS

- Reduce the risks of caravan or trailer jack-knifing, skidding and trailer sway during emergency braking situations
- Improved braking performance through increased brake outputs
- Increases control during evasive procedures on the road